

L7

LINEAR AMPLIFIER

by



DRAKE



LIMITED WARRANTY

R. L. DRAKE COMPANY warrants to the original purchaser that this product shall be free from defects in material (except tubes and RF output transistors) or workmanship for ninety (90) days from the date of original purchase.

During the warranty period the R. L. DRAKE COMPANY or an authorized Drake service facility will provide free of charge both parts (except tubes and RF output transistors) and labor necessary to correct defects in material or workmanship.

To obtain such warranty service, the original purchaser must:

- (1) Complete and send in the Warranty Registration Card.*
- (2) Notify R. L. DRAKE COMPANY or its nearest authorized service facility, as soon as possible after discovery of a possible defect, of:*
 - (a) The model number and serial number, if any;*
 - (b) The identity of the seller and the approximate date of purchase;*
 - (c) A detailed description of the problem, including details on the electrical connection to associated equipment and the list of such equipment.*
- (3) Deliver the product to the R. L. DRAKE COMPANY or the nearest authorized service facility, or ship the same in its original container or equivalent, fully insured and shipping charges prepaid.*

Correct maintenance, repair and use are important to obtain proper performance from this product. Therefore, carefully read the Instruction Manual. This warranty does not apply to any defect that R. L. DRAKE COMPANY determines is due to:

- (1) Improper maintenance or repair, including the installation of parts or accessories that do not conform to the quality and specifications of the original parts.*
- (2) Misuse, abuse, neglect or improper installation.*
- (3) Accidental or intentional damage.*

All implied warranties, if any, terminate ninety (90) days from the date of the original purchase.

The foregoing constitutes R. L. DRAKE COMPANY'S entire obligation with respect to this product, and the original purchaser and any user or owner shall have no other remedy and no claim for incidental or consequential damages. Some states do not allow limitations on how long an implied warranty lasts or do not allow the exclusion or limitation of incidental or consequential damages, so the above limitation and exclusion may not apply to you.

This warranty gives specific legal rights and you may also have other rights which vary from state to state.

R. L. DRAKE COMPANY
540 Richard Street • Miamisburg, Ohio 45342



OPERATOR'S MANUAL

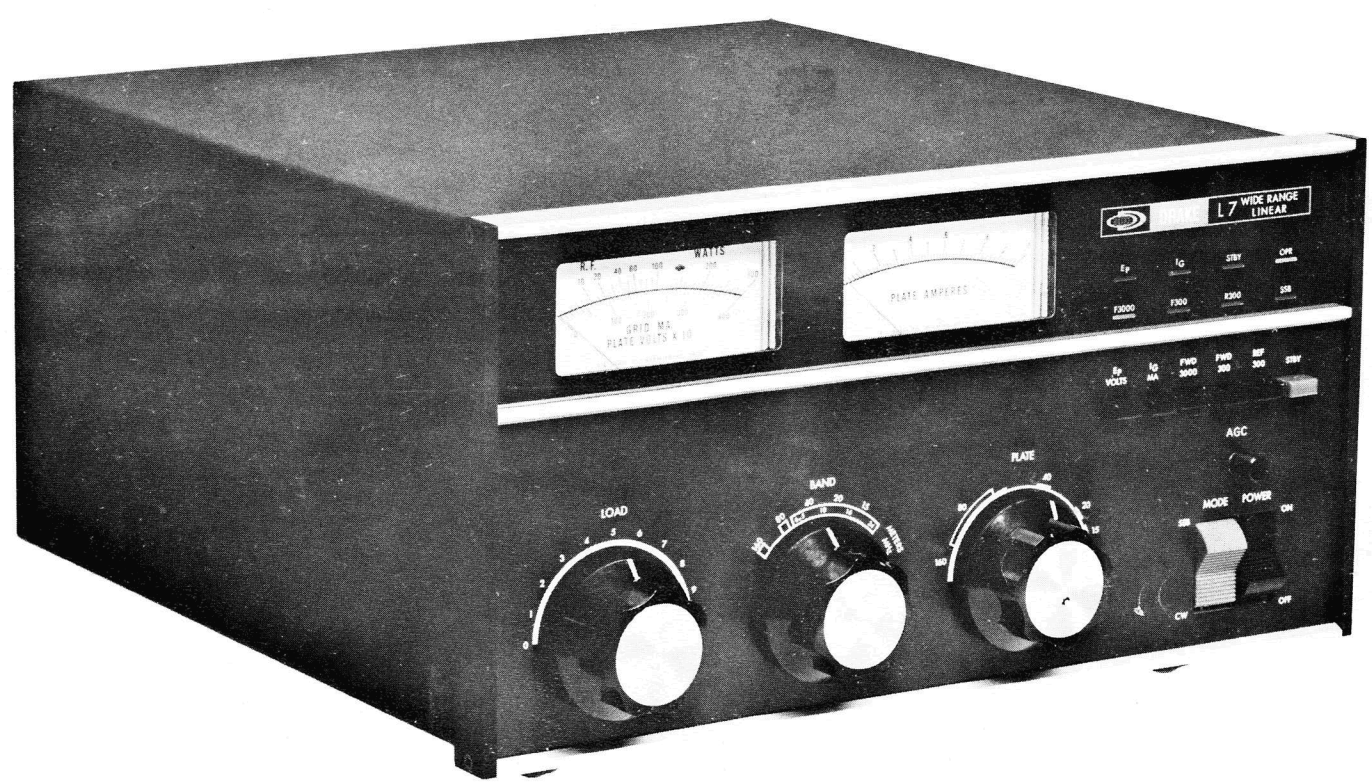

L7

LINEAR AMPLIFIER

© R. L. DRAKE COMPANY 1979

PRINTED IN U.S.A.

TABLE OF CONTENTS

	PAGE
CHAPTER 1 INTRODUCTION	1-1
1-1. GENERAL DESCRIPTION.....	1-1
1-2. MANUAL COVERAGE	1-1
CHAPTER 2 INSTALLATION	2-1
2-1. UNPACKING	2-1
2-2. TUBE INSTALLATION	2-1
2-3. LOCATION	2-1
2-4. POWER REQUIREMENTS.....	2-2
2-5. JUMPER CONNECTIONS	2-2
2-6. ANTENNA REQUIREMENTS	2-2
2-7. LOW PASS FILTER	2-2
2-8. MATCHING NETWORK	2-2
2-9. GROUND REQUIREMENTS	2-2
2-10. EXCITER REQUIREMENTS	2-2
2-11. TRANSMITTING AGC	2-2
2-12. VOX RELAY	2-3
CHAPTER 3 OPERATION	3-1
3-1. GENERAL	3-1
3-2. TUNING PROCEDURE	3-1
3-3. CW AND RTTY TUNING	3-1
3-4. SSB AND AM TUNING	3-1
3-5. OPERATION	3-3
3-6. CW AND RTTY OPERATION	3-3
3-7. SSB OPERATION	3-3
3-8. AM OPERATION	3-3
3-9. SWR CALCULATION	3-3
3-10. OPERATION ON ACCESSORY FREQUENCIES	3-4
CHAPTER 4 THEORY OF OPERATION.....	4-1
4-1. INPUT	4-1
4-2. TRANSMITTING AGC	4-1
4-3. STANDBY CUTOFF BIAS	4-1
4-4. OUTPUT	4-1
4-5. WATTMETER.....	4-1
CHAPTER 5 MAINTENANCE	5-1
5-1. SERVICE DATA.....	5-1
5-2. PARTS ORDERING.....	5-1
5-3. AMPLIFIER DISASSEMBLY	5-1
5-4. CLEANING	5-1

	PAGE
5-5. TUBE REPLACEMENT	5-1
5-6. TEST EQUIPMENT	5-1
5-7. AMPLIFIER TROUBLESHOOTING	5-2
5-8. TUBE CHECK	5-2
5-9. ALIGNMENT PROCEDURES	5-2
5-10. INPUT COIL ADJUSTMENT	5-3
5-11. METER ADJUSTMENT	5-3
5-12. WATTMETER CALIBRATION	5-3
5-13. NULL ADJUSTMENT	5-3
5-14. 300 WATTS REFLECTED	5-3
5-15. 300 WATTS FORWARD	5-3
5-16. 3000 WATTS FORWARD	5-4
5-17. KNOB POINTER ALIGNMENT	5-4
5-18. POWER SUPPLY CIRCUIT BREAKER RESET	5-4
5-19. REMOVING THE BOTTOM COVER	5-4
5-20. REMOVING TOP COVER	5-4
5-21. POWER SUPPLY TROUBLESHOOTING	5-4

LIST OF ILLUSTRATIONS

Figure		Page
1-1	MODEL L7 LINEAR AMPLIFIER	1-2
2-1	REAR CHASSIS CONNECTORS	2-4
2-2	JUMPER CONNECTIONS FOR 120 VOLT OPERATION.....	2-5
2-3	JUMPER CONNECTIONS FOR 240 VOLT OPERATION.....	2-5
2-4	CONNECTING THE PS-7 POWER SUPPLY AND THE R. L. DRAKE LINE OF COMPATIBLE EXCITERS	2-6
2-5	VIEWING ANGLE OPTIONS	2-7
3-1	FRONT PANEL CONTROLS	3-2
3-2	PLATE VOLTAGE AND PLATE CURRENT VS 1,000 WATTS DC INPUT POWER	3-5
3-3	SWR NOMOGRAPH	3-5
5-1	COMPONENT LOCATIONS, TOP VIEW.....	5-5
5-2	COMPONENT LOCATIONS, BOTTOM VIEW.....	5-6
5-3	CONNECTIONS FOR GRID CURRENT METER CALIBRATION	5-7
5-4	MODEL L7 POWER SUPPLY SCHEMATIC DIAGRAM.....	5-7
5-5	MODEL L7 LINEAR AMPLIFIER SCHEMATIC DIAGRAM.....	5-9

CHAPTER 1

INTRODUCTION

1-1. GENERAL DESCRIPTION

The R. L. Drake Model L 7 Linear Amplifier offers continuous 2000 Watts PEP on SSB, and 1000 Watts DC on CW, AM (controlled carrier) and RTTY operation covering the ham bands 160 through 15 meters. Non-amateur frequencies between 1.8 and 21.5 MHz may be covered with modification of the input circuit.

The L 7 uses 2 zero-bias triodes in a Class B grounded-grid circuit configuration that utilizes RF negative feedback for lower odd-order distortion products. As shipped from the factory, these tubes will be one of the following listed parts, which are interchangeable but which are furnished in pairs only:

Amperex 8802/3 — 500Z

Amperex 8163

Eimac 3 — 400Z

Eimac 3 — 500Z

The tubes are cooled by a quiet, dual-speed internal blower.

A transmitting AGC circuit controls the exciter gain to allow the highest average power without peak clipping. An internal changeover relay feeds

the antenna through when the L 7 is turned off. A pair of relay contacts bias the output tubes to cut-off, eliminating unwanted heat and diode noise when receiving. Two meters indicate plate current, grid current, plate voltage, RF output power, and RF reflected power. The separate solid state Power Supply requires no warm-up period and provides excellent dynamic and static voltage regulation.

1-2. MANUAL COVERAGE

This manual is presented in 5 chapters with supporting illustrations and is arranged for the convenience of the operator and service technician as follows:

- Chapter 1 Introduction (self explanatory).
- Chapter 2 Installation. Describes the procedures to be followed prior to operation.
- Chapter 3 Operation. Illustrates and describes front panel controls and describes tune-up and operation in SSB, CW, RTTY, TUNE and AM modes.
- Chapter 4 Theory of Operation. Describes all critical circuits and networks.
- Chapter 5 Maintenance. Provides maintenance instructions, troubleshooting and parts ordering information.

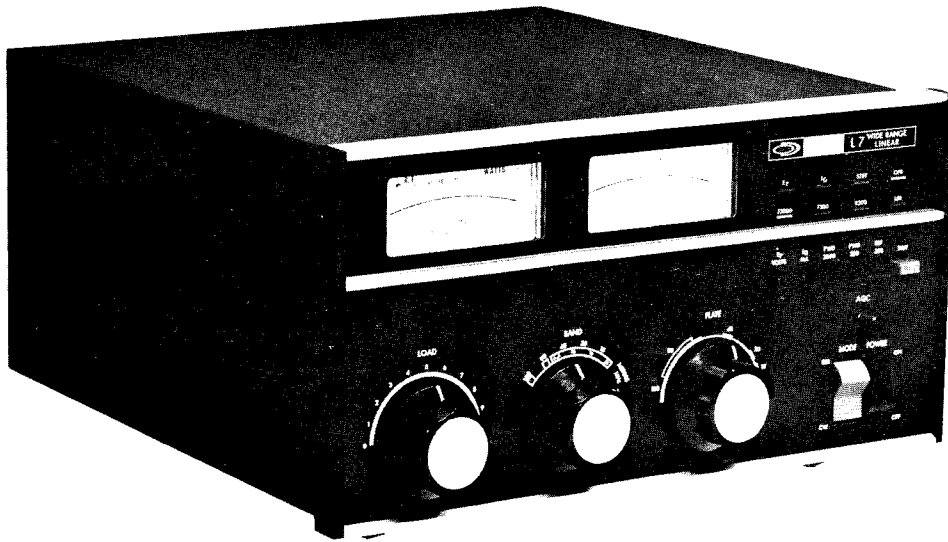

Fig. 1-1 Model L7 Linear Amplifier

SPECIFICATIONS

Frequency Coverage:	Ham bands 160 through 15 meters. Non-amateur frequencies between 1.8 and 4.0, 6.5 and 21.5 MHz may be covered with some modification of the input circuit.		
Plate Input:	2000 Watts PEP on SSB and 1000 Watts DC on CW, AM and RTTY.	Power Requirements:	240 Volts 50-60 Hertz 15 Amperes, or 120 Volts 50-60 Hertz 30 Amperes.
Drive Requirements:	100 Watts PEP on SSB and 75 Watts on CW, AM and RTTY.	Tube Complement:	Two of 3-500Z or 8802/3-500Z or 3-400Z.
Input Impedance:	50 Ohms (Band Pass Tuned Input).	Dimensions:	Amplifier 13-11/6 in. W x 6-3/4 in. H x 14-1/4 in. D. (34.8 cm W x 17.1 cm H x 36.2 cm D.) Power Supply 6-3/4 in. W x 7-7/8 in. H x 11 in. D. (17 cm W x 20 cm H x 28 cm D.)
Output Impedance:	Adjustable pi-network matches 50 ohm line with SWR not to exceed 2:1.	Weight:	Amplifier - 27 lbs. (12.25 kg.) Power Supply - 42.5 lbs. (19.3 kg.)
Intermodulation		* Export model includes coverage of 10 meter Ham Band.	
Distortion Products:	In excess of -33 dB.		
Wattmeter Accuracy:	300 Watts forward and reflected, \pm (5% of reading + 3		

CHAPTER 2 INSTALLATION

WARNING

The L 7 has been designed incorporating several interlocks to prevent dangerous electrical shock. However, it is possible to disconnect the high voltage terminal while the L 7 is turned on. This is *EXTREMELY DANGEROUS* and never should be attempted for any reason. When disassembling the L 7, the high voltage terminal should be disconnected *LAST* and at reassembly the high voltage terminal should be connected *FIRST*. The L 7 and its Power Supply can be installed and serviced in complete safety if the instructions in this manual are followed explicitly.

2-1. UNPACKING

The L7 Linear Amplifier is shipped from the factory in 3 separate cartons; 1 contains the Amplifier and miscellaneous hardware, 1 contains the Power Supply and the third contains the tubes. Carefully unpack all three cartons and examine their contents for evidence of shipping damage. If any damage is discovered, notify the transportation company that delivered the equipment. Be sure to keep the cartons and packing material as the transportation company will want to examine them. Keep the carton and packing even if no shipping damage occurs. Having the original cartons available simplifies repacking the equipment for storage or to return it to the factory for service. Inspect the packing material closely before storing it to be sure that none of the accessory hardware has been overlooked. The dismantled components and accessory hardware shipped with the L7 should be checked against the following list:

- a. 2 tubes (Amplifier V1 and V2)
- b. 2 Plate Caps (for Tubes)
- c. (2) 6-32×5/8 screws (for Plate Caps)
- d. 2 Parasitic Chokes (Note TOP label)
- e. (2) 6-32×1/4 screws (connect Chokes to Caps)
- f. 2 Resistors, 0.82 Ohm, 2 Watts (Replacement spares for Power Supply R12)
- g. 2 Cables (1 Vox Relay, 1 Transmit AGC)
- h. 2 Resistors, 0.82 Ohm, 2 Watts (Replacement spares for Power Supply R12)
- i. 2 Rubber Feet (For Viewing Option B)
- j. 2 Studs (to attach rubber feet)
- k. 1 Instruction Manual (READ IT)

1. 1 Warranty Registration Card

NOTE

Fill out the enclosed Warranty Registration card and return it to the factory immediately to insure registration and validation of the warranty.

2-2. TUBE INSTALLATION

WARNING

Tubes must be installed and the cabinet replaced **BEFORE ANY CONNECTIONS** are made to the L 7.

- a. Remove the 6 screws which secure the cabinet to the amplifier and remove the cabinet.
- b. Refer to figure 5-1. Insert both tubes into the sockets on the amplifier chassis.
- c. Install the plate caps on the tubes and secure them with the screws provided.
- d. Attach the parasitic chokes to the top of each of the plate caps with the screws and lockwashers provided. Make sure that the coils of the two chokes hang **DOWN**. The word **TOP** stamped on each choke must be visible from the top of the amplifier.
- e. Attach both of the remaining leads on the parasitic chokes to the top of the plate RF choke using the 1/4-20 aluminum screw which also secures one lead from the coupling capacitors. **DO NOT** overtighten this screw.
- f. Replace the cabinet and secure it with the 6 screws removed in step a.

2-3. LOCATION

In general, the location of the L 7 is not critical; however, there are certain considerations which must be given to insure optimum performance. Care should be taken to insure that a space is provided around the Power Supply case to allow adequate air circulation. Extremely hot locations, such as near radiators or heating units, should be avoided. The back of the Amplifier case must not be obstructed and should not be placed closer than 1 inch from a wall or the air inlet for the blower will be blocked and overheating of the tubes may occur.

2-4. POWER REQUIREMENTS

The L 7 is furnished with its own separate Power Supply which can be operated from either 120 VAC or 240 VAC 50-60 Hertz. Because of the large variety of plug and socket configurations for 240 volt service, and because the L 7 can be operated from either 120 Volts or 240 Volts, a line plug is not furnished with the L 7. The L 7 is shipped from the factory with jumpers connected to operate on 240 VAC. It is highly recommended that the L 7 be operated from its own 240 Volts (15 Amps or greater) circuit. If a 120 Volt circuit is all that is available, it should be fused for 30 Amps and the circuit conductors should not be less than No. 10. No other equipment should be operated from this circuit. DO NOT under any circumstances operate the L 7 from a 120 Volt lighting circuit because the circuit conductors are not large enough to carry this load safely.

2-5. JUMPER CONNECTIONS

Figures 2-2 and 2-3 are diagrams of jumper connections required for 120 and 240 Volt operation. The jumpers in *both* the Amplifier and Power Supply *must* be connected as shown or serious damage to the L 7 components may result.

2-6. ANTENNA REQUIREMENTS

The L 7 has been designed for use with antennas resonant at the operating frequency and having approximate impedances within the limits of 25 to 100 Ohms. The nominal output impedance of the amplifier is 50 Ohms and the SWR of this load should never exceed 2:1. Although there are many types of antennas which will meet these requirements, the simplest is a one-half wave dipole center fed with 52 Ohm coax. For a detailed discussion on antennas, refer to an appropriate antenna book.

2-7. LOW PASS FILTER

The amplifier has been designed in accordance with good engineering practices, and harmonic attenuation meets or exceeds current FCC specifications. Because of the possibility that you may be using a multiband antenna or have a feed line that is resonant at a harmonic frequency, it is highly recommended that a suitable low pass filter such as the R. L. Drake Model TV-3300-LP be used with the L 7.

2-8. MATCHING NETWORK

Most practical antennas exhibit an SWR range over a complete amateur band that exceeds 2:1. For this reason we recommend using an antenna matching network such as the R. L. Drake MN-2700 which will allow the L 7 to work into a 50 Ohm load for maximum power transfer into the antenna.

CAUTION

Never attempt to operate the L 7 without first connecting to an antenna or 50 Ohm Dummy Load of sufficient power handling capacity or serious damage may result.

2-9. GROUND REQUIREMENTS

For best results, the amplifier should be attached to a good earth ground through as short and as large a ground strap as possible. A binding post is provided on the rear of the amplifier chassis for the ground connection. It is always a good idea to connect the chassis of all associated equipment together and ground them at one point to avoid ground loops. We recommend that all of the equipment in your station be connected together and grounded at the L 7 Amplifier chassis.

2-10. EXCITER REQUIREMENTS

To operate the amplifier at the maximum legal input the exciter must provide 100 Watts PEP RF power for SSB operation and 75 Watts RF power for CW, AM, RTTY and TUNE operation. Locate the exciter as close to the amplifier as practical to shorten the coaxial cable and ground strap. Refer to figures 2-4 and 2-5 for recommended connection arrangements.

2-11. TRANSMITTING AGC

The transmitting AGC voltage, which controls the gain of the exciter, is presented at a connector labeled XMTG AGC OUTPUT on the rear of the L 7. Any power level can be run up to 2000 Watts PEP without peak clipping. A cable is furnished with the amplifier which provides a connection to the R. L. Drake PS-7 or AC-4 Power Supply. This connection is routed through the power supply to the transmitter.

2-12. VOX RELAY

A phono jack on the rear of the L7 Amplifier is provided for connection to a pair of normally open relay contacts in the exciter, which close on transmit and thus turn on the amplifier at the same time. The L7 is supplied with a cable with phono plugs on each end for this purpose. AC-4 and early PS7 Power Supplies are equipped with a 'two' pin connector instead of a phono jack for this connection.

For TR7's and similar exciters, it is necessary to observe the correct polarity when connecting the VOX RELAY circuit. If a phono connector is used this is automatically accomplished. If a two pin connector is used, the correct polarity is obtained with the following procedure. Place the exciter in STANDBY and set the L7 MODE switch to CW, the ON/OFF switch to ON, and the STBY switch in the "operate" (out) position. Plug in the VOX cable connectors and observe the Plate Current Meter. If it reads upscale, reverse the two pin VOX connector on the exciter end. The amplifier plate current must be zero with the VOX cable plugged in and the exciter in STANDBY.

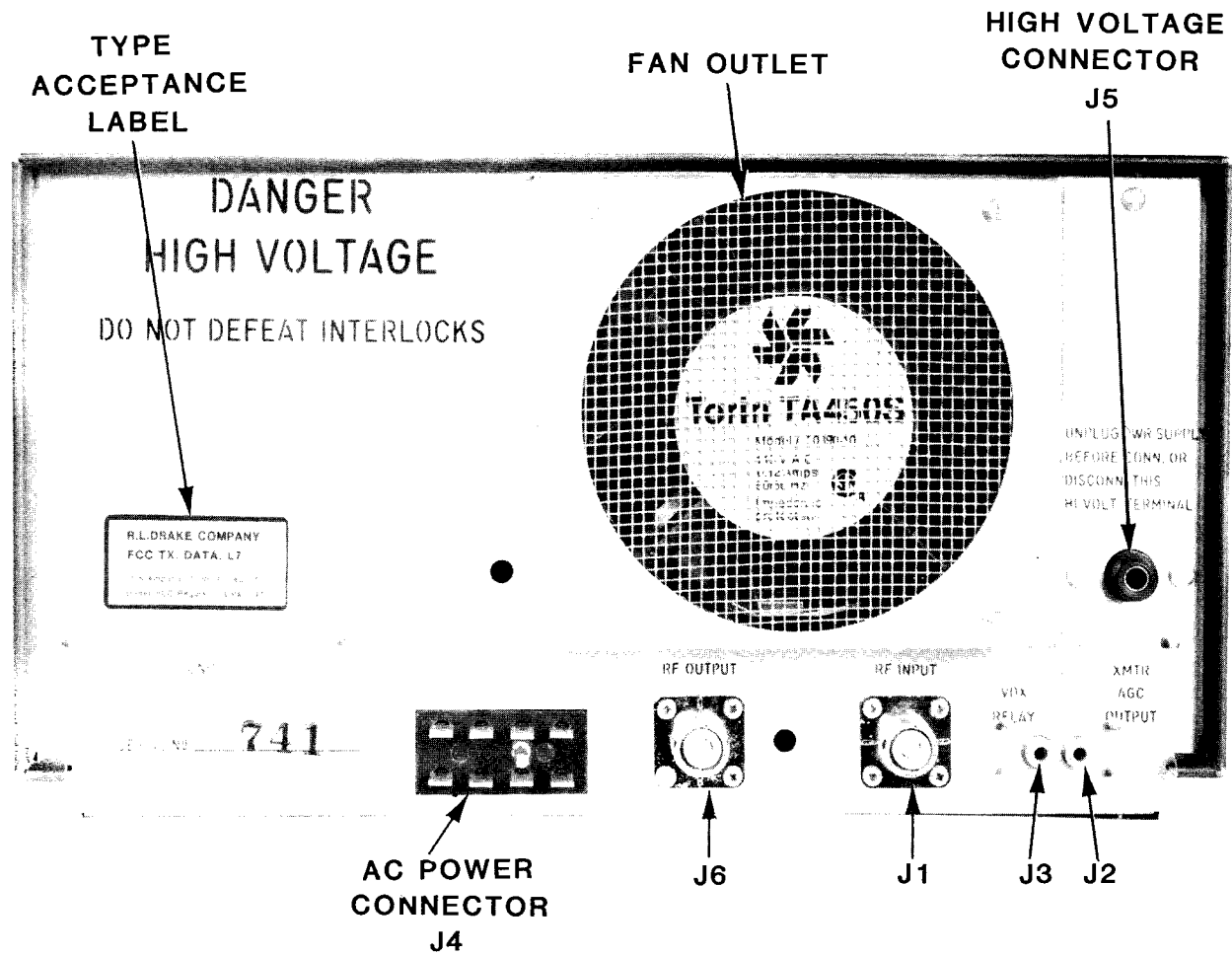

Fig. 2-1 Rear Chassis Connectors

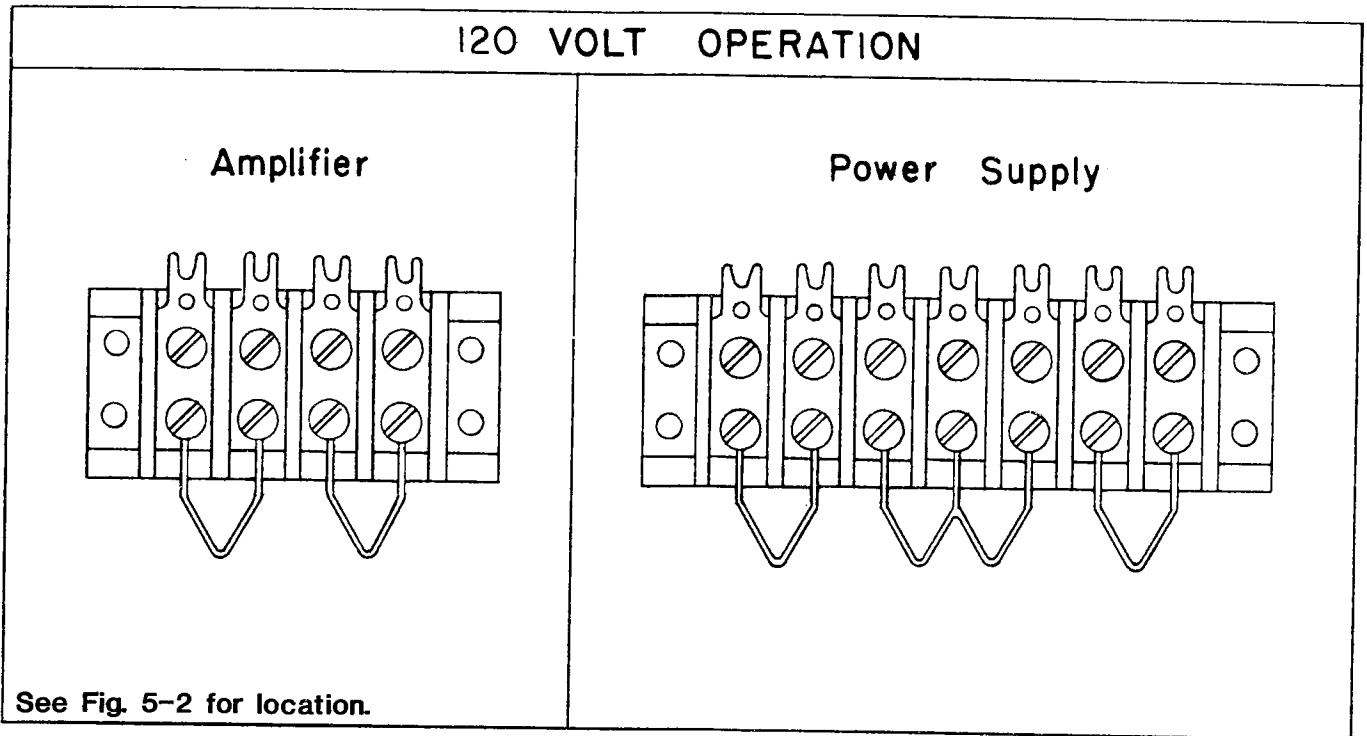

Figure 2-2. Jumper Connections for 120 Volt Operation

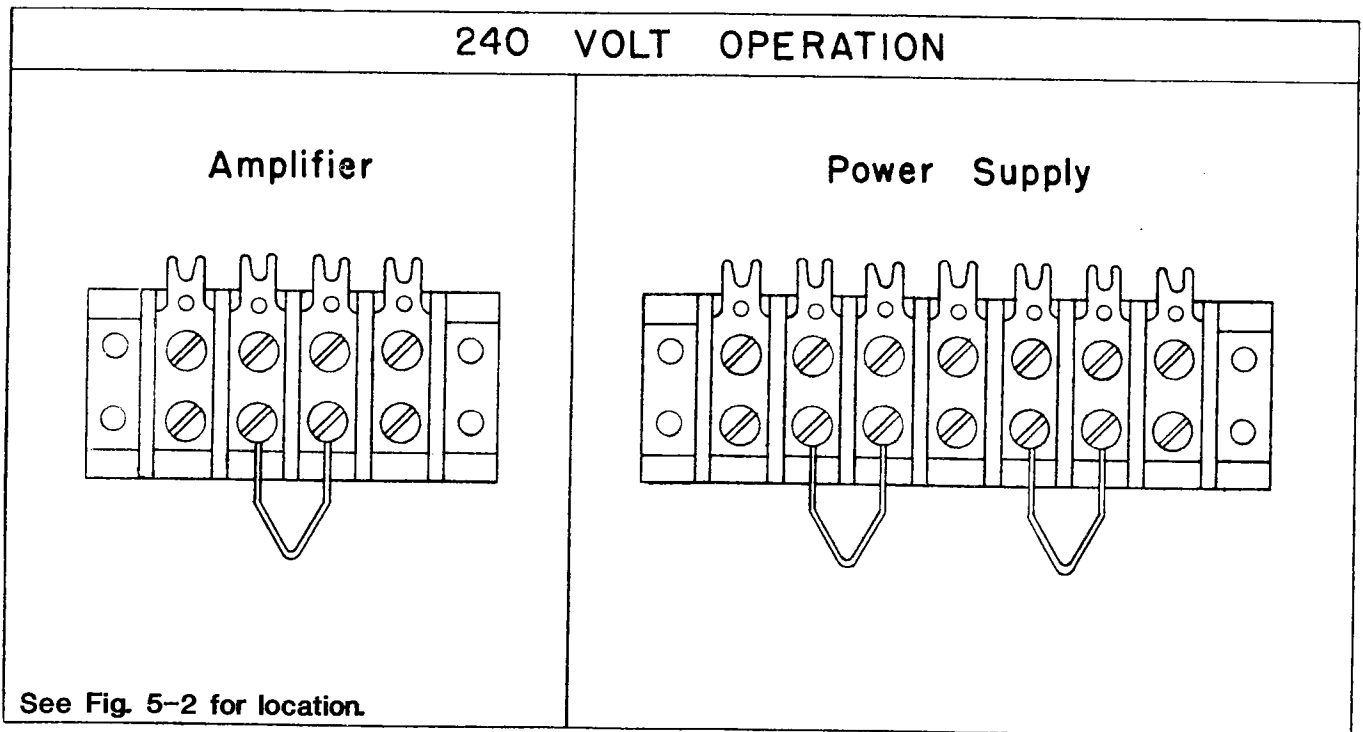
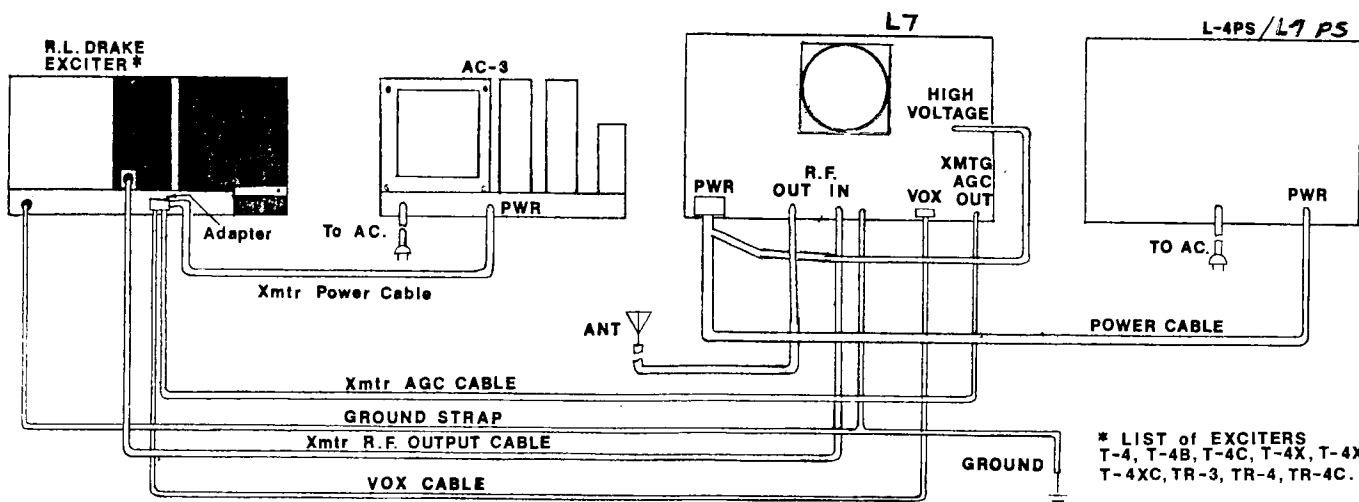
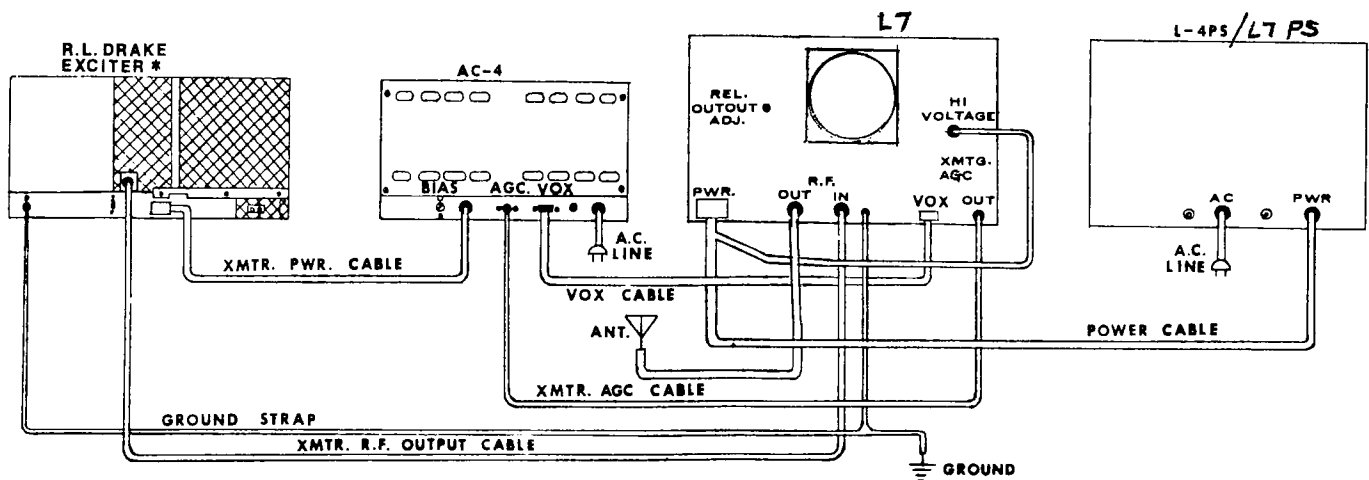

Figure 2-3. Jumper Connections for 240 Volt Operation



* LIST of EXCITERS
 T-4, T-4B, T-4C, T-4X, T-4XB
 T-4XC, TR-3, TR-4, TR-4C.

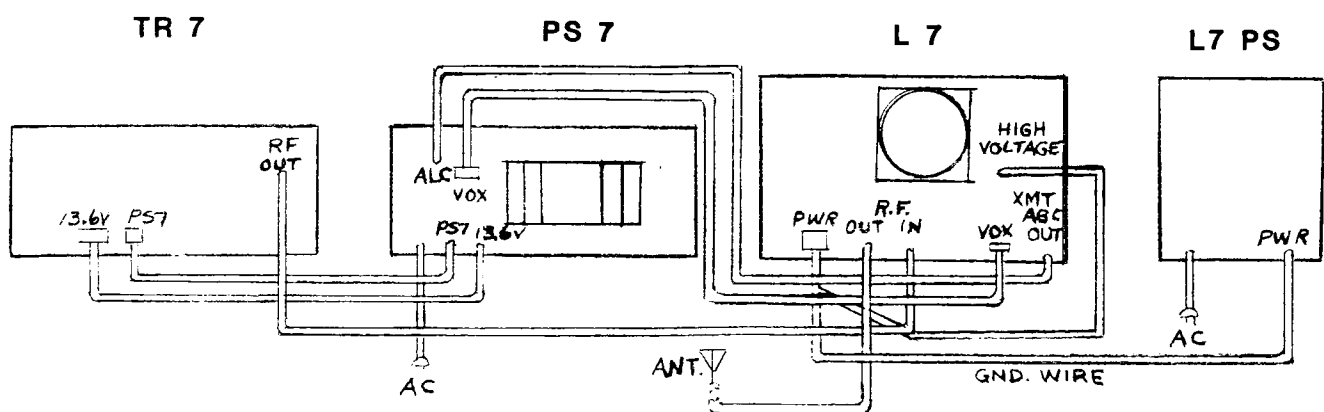
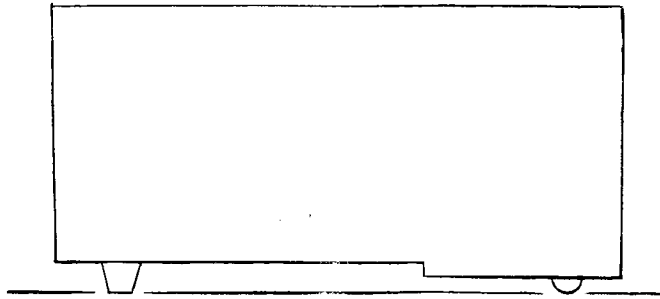
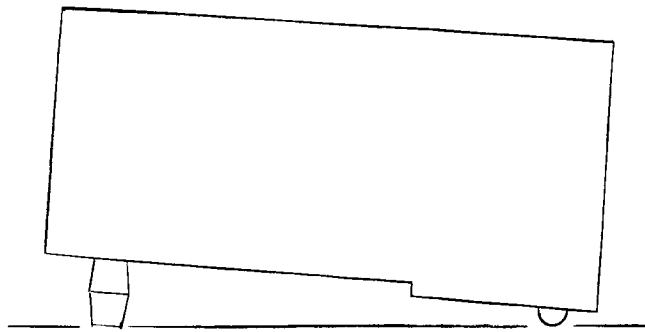

Fig. 2-4 Connecting the PS-7 Power Supply and the R. L. Drake Line of Compatible Exciters



OPTION A



OPTION B

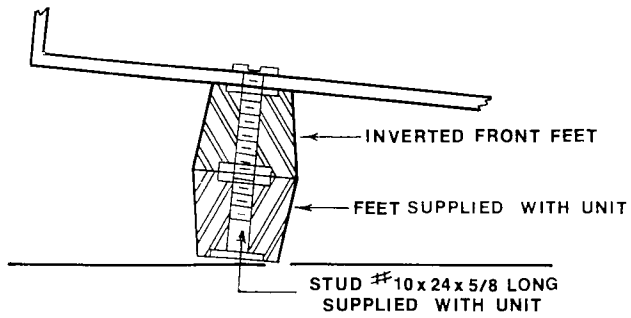

Fig. 2-5 Viewing Angle Options

NOTES

CHAPTER 3 OPERATION

CAUTION

DO NOT turn on the L 7 Amplifier with the cabinet removed because the high voltage inter-lock shorts out the B+ and will damage Power Supply components. *DO NOT* operate the Linear Amplifier until it has been connected to a 50 Ohm antenna or a 50 Ohm Dummy Load. Be sure that the correct jumper connections described in Chapter 2 have been made in both the Linear Amplifier and the Power Supply for the line voltage to be used.

3-1. GENERAL

Figure 3-1 identifies and describes all front panel controls and indicators referred to in these tuning and operating procedures. Perform the appropriate tuning procedures described below prior to operation.

For all modes of operation, the L 7 is tuned up with a single RF frequency driving it and with the Mode switch in CW position. The exciter may be tuned up on CW into the antenna connected to the amplifier by depressing the STBY switch. The exciter should be checked to be sure that it is tuned up when driving the L 7 since the antenna connected to the amplifier may not be exactly 50 Ohms.

3-2. TUNING PROCEDURE

After the exciter has been tuned up, turn the exciter to standby and release the STBY switch on the L 7. Set the Mode switch (red rocker switch) to CW position. The light that indicates high plate voltage for SSB operation should be off, and the OPR light should be on.

The Drake TR 7 and some other exciters utilize transmitting AGC, sometimes called ALC, during all modes of operation. During tune up, transmitting AGC will have to be defeated either by unplugging the transmitting AGC connector, or by turning the AGC control fully counterclockwise. All Drake Transmitters and Transceivers except the TR 7 and 2-NT (which has no transmitting AGC) switch off AGC in TUNE, CW and AM modes. It is not necessary to defeat AGC externally on Drake Transmitters, other than the TR-7.

3-3. CW AND RTTY TUNING

Preset the front panel controls on the L 7 as follows:

- a. Mode switch to CW.
- b. Band switch to desired band.
- c. Meter switch to 3000 WATTS FWD.
- d. STBY switch to "operate" (out).
- e. LOAD fully counterclockwise to zero.
- f. PLATE control in the arc provided for the desired band.
- g. Turn AGC control fully counterclockwise.
- h. ON-OFF switch to ON.

Turn on the exciter and increase the exciter output while not exceeding 0.400 Amperes plate current. Tune the PLATE control for a dip in plate current. Alternately adjust the LOAD and PLATE controls while increasing the exciter power in small increments until maximum RF output occurs at 0.565 plate Amperes. Because of variations in line voltage a graph (figure 3-2) is supplied which correlates plate voltage and plate current for 1000 Watts DC plate input power and should be used to be sure that the amplifier is operating at or under the maximum legal input power. In case maximum legal input cannot be obtained because of low exciter power, tune for maximum forward RF Watts at maximum exciter power.

3-4. SSB AND AM TUNING

Preset the front panel controls on the L 7 as follows:

- a. Mode switch to CW.
- b. Band switch to desired band.
- c. Meter switch to IG (grid current).
- d. LOAD control fully counterclockwise to zero.
- e. Plate control in the arc provided for the desired band.
- f. Turn AGC control fully counterclockwise.
- g. STBY switch to "operate" (out).
- h. ON-OFF switch to ON.

NOTE

Substitute 250 mA grid current for 200 mA in succeeding test if Amperex 8802/3-500Z tubes are installed in the amplifier.

Turn on the exciter and increase the exciter output while not exceeding 0.400 Amperes plate current and tune the PLATE control for a dip in plate current. While increasing the exciter power, maintain

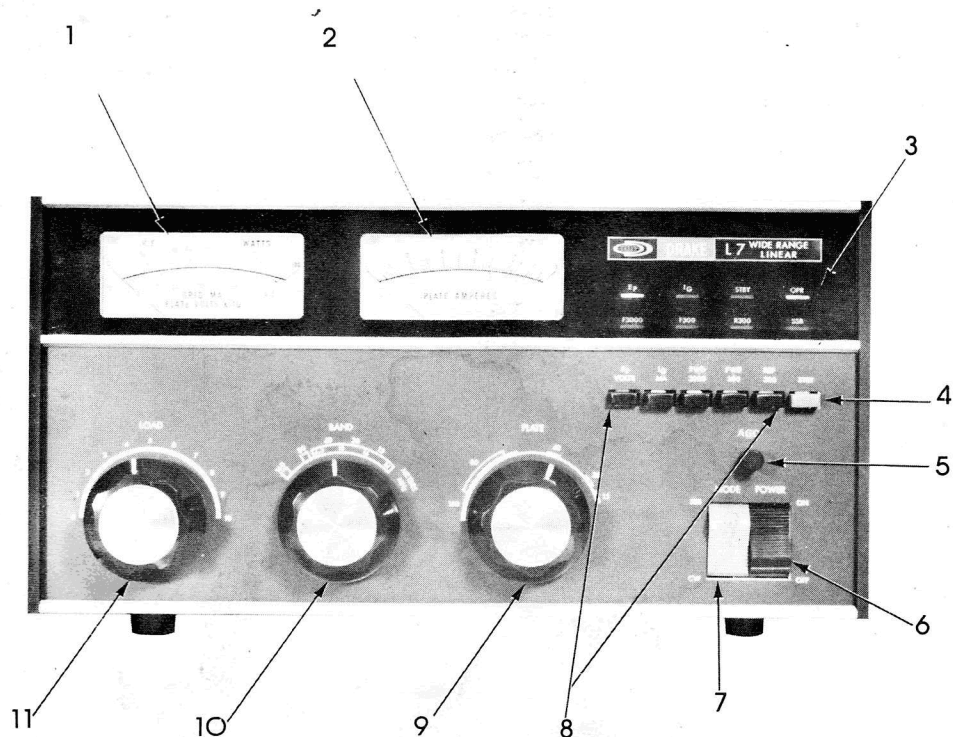

FIGURE 3-1. FRONT PANEL CONTROLS

1. *Multimeter: Indicates plate voltage, grid current, and forward or reflected watts as selected by meter switches (8).*
2. *Plate Current Meter: Indicates plate current.*
3. *Indicator Lamps: Indicate standby or operate condition, SSB (high power) mode, and multimeter function.*
4. *STBY Switch: When depressed, allows standby operation with the exciter connected straight through to the antenna.*
5. *AGC Control: Adjusts the transmitting AGC threshold.*
6. *ON/OFF Switch: Turns the main power on and off.*
7. *MODE Switch: Selects high plate voltage for SSB operation or low plate voltage for CW operation or for tuning.*
8. *Meter Switches: Select indication for Multimeter (1).*
9. *PLATE Control: Resonates the plate tank circuit.*
10. *BAND Switch: Selects input and plate tank components to resonate the amplifier on the selected band.*
11. *LOAD Control: Adjusts the output impedance of the amplifier to match the antenna load impedance.*

220 mA of grid current with the LOAD control until 0.565 plate Amperes is reached. Leave the exciter power at this level and redip the plate current with the PLATE control and then bring the grid current back to 220 mA with the LOAD control. The L-7 will be very close to being tuned up and only small adjustments of the driving power, and PLATE and LOAD controls will be necessary to obtain 0.565 plate Amperes with 220 mA grid current at resonance.

The forward power meter is a more sensitive indication of plate tank resonance than plate current dip, and the PLATE control should be adjusted for maximum forward power while still maintaining the relationship of 0.565 plate Amperes to 220 mA grid current. In case 0.565 plate Amperes cannot be reached because of low exciter power, tune the amplifier for maximum forward RF Watts at maximum exciter power.

3-5. OPERATION

NOTE

While transmitting with the L 7 over extended periods of time, the final amplifier plates may show a bright red color. This is normal and does not detract from the life of the tubes. If the plates display a very bright orange color it is advisable to check the amplifier to determine that it is not being overdriven and that it is tuned up properly. The power should not be turned off immediately after long periods of transmitting, but the amplifier should be left on standby for several minutes with zero plate Amperes to allow the final amplifier tubes to cool down.

3-6. CW AND RTTY OPERATION

For CW and RTTY operation the Mode switch should be in CW position. With the exciter on and the key depressed, adjust the drive level until the product of plate voltage and plate current is at or under maximum legal input power.

3-7. SSB OPERATION

For SSB operation the Mode switch should be in SSB position and the red light that indicates high plate voltage ("SSB") should be on. The transmitting AGC threshold must be set before using the amplifier. With the Mode switch in CW position the transmitting AGC threshold is adjusted by applying a strong single audio tone into the

microphone input of the exciter either by an oscillator or by whistling a single tone into the microphone with the exciter adjusted for maximum output. With this single tone applied, turn the AGC control clockwise until the plate current is 0.580 Amperes. If you desire to run less than 2 kilowatts PEP, turn the AGC control clockwise until the single tone plate current decreases to the power level you desire. Return the Mode switch to SSB. The AGC threshold needs to be set once on each band. When making large changes in frequency within a band, the amplifier should be checked for plate tank resonance while still maintaining the relationship of 0.565 plate Amperes to 220 mA grid current on CW. Under normal voice operating conditions, the exciter should be adjusted to run the L 7 Plate Meter between 0.300 to 0.400 Amperes. Plate current of .400 Amperes is the maximum legal input allowed and this level should be reached only occasionally and never exceeded. If the exciter has no provisions for transmitting AGC, the output from the amplifier should be monitored with an oscilloscope to check for peak clipping.

3-8. AM OPERATION

For AM operation the Mode switch should be in SSB position and the red light that indicates high plate voltage ("SSB") should be on. The L 7 works quite favorably on AM with the compatible Drake line of Transceivers and Transmitters since these units use controlled carrier modulation. Transmitting AGC is not used on AM with the Drake units, and the amplifier output should be monitored with an oscilloscope to check for peak clipping. If the L 7 is to be used with a 100% modulated AM transmitter, the exciter should be adjusted to run the amplifier at 500 Watts DC input with an unmodulated carrier.

3-9. SWR CALCULATION

The SWR of the load connected to the amplifier can be determined by using the forward and reflected power readings from the L 7 wattmeter and the SWR calculator. Refer to figure 3-3. The calculator is used by laying a straight-edge across the scales at the forward and reflected meter readings and reading the VSWR straightedge. The L 7 wattmeter indicates forward and reflected power at all times, so that SWR can be calculated using only the exciter. For measuring the exciter RF output power a higher degree of accuracy can be obtained by using the 300 Watt forward scale

instead of the 3000 Watt scale. When returning the amplifier to service, be sure to return the Meter switch to 3000 Watts or the wattmeter may be damaged. The amount of RF power delivered to the load can be determined by subtracting the reflected power from the forward power.

3-10. OPERATION ON ACCESSORY FREQUENCIES

Bandswitch Position	Frequency in MHz
160	1.8 - 2.0
80	3.2 - 4.5
40	6.5 - 10
20	10 - 16
15	16 - 21.5

The input coils may be retuned for frequencies moderately removed from the amateur bands. For frequencies far removed, it may be necessary to change the values of the capacitors in the input circuit.

1000 Watts D.C. Input
VS
Plate Voltage and Plate Amperes

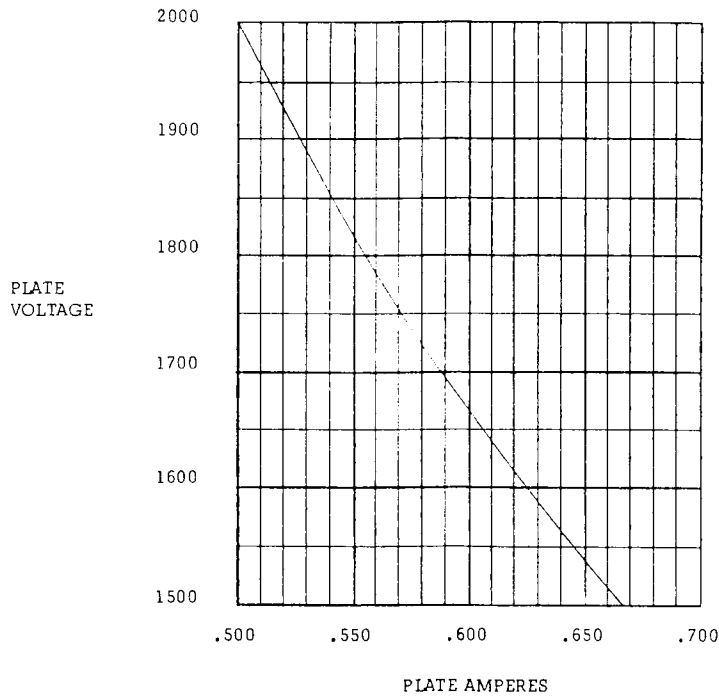

Figure 3-2. Plate Voltage and Plate Current VS 1,000 Watts DC Input Power

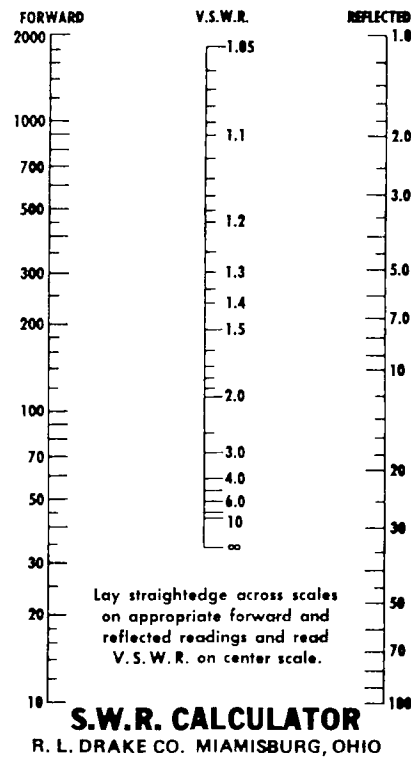

Figure 3-3. SWR Nomograph

NOTES

CHAPTER 4

THEORY OF OPERATION

4-1. INPUT

Refer to the schematic diagrams figures 5-4 and 5-5. The 50 ohm input is matched to the final amplifier cathodes by a pi-network on each band which is selected by the input switch S1. The input switch is ganged to the plate circuit bandswitch S1B. Negative feedback in the L 7 Amplifier is obtained by slightly raising the grids above ground with capacitors C19, C20, C21, C24, C25, and C27.

4-2. TRANSMITTING AGC

When the negative-going peak RF voltage from the capacitor divider C17 and C18 exceeds the positive bias set by R4, the transmitting AGC threshold control, CR1 conducts and a negative voltage proportional to the RF signal applied to the input appears at the transmitting AGC output connector.

4-3. STANDBY CUTOFF BIAS

A positive voltage from the resistor divider, R9, R10 and R11 in the Power Supply is applied to the cathode during standby which cuts off the plate current.

4-4. OUTPUT

The plate circuit is matched to the 50 ohm output by the adjustable pi-network consisting of L9-L11, C42, C43 and C46-C50.

4-5. WATTMETER

The directional wattmeter basically consists of L13, C53, C54 and C55, which take the sum and difference of the transmission line phase voltages and currents to indicate forward and reflected RF power. CR4, CR5, C56, C57, R23, R25 and R26 rectify, filter and multiply the basic 200 μ A movement of the front panel meter M2 to indicate forward and reflected RF power.

NOTES

CHAPTER 5 MAINTENANCE

5-1. SERVICE DATA

Your L 7 will be checked and aligned at the factory for a nominal fee if it has not been tampered with. Transportation charges are extra. Any necessary repairs will be made on a time and material basis. Please write or call the factory for authorization before returning your unit for alignment or service. Address your request for authorization to:

R. L. Drake Company
540 Richard Street
Miamisburg, OH 45342

ATTN: Customer Service Department
Telephone: (Area Code 513) 866-3211

CAUTION

DO NOT ship the L 7 with the tubes installed. If the tubes are in question remove them and re-pack them separately in their original shipping containers or obtain new containers from R. L. Drake Company at the address listed above. The R. L. Drake Company will not assume responsibility if the transportation company refuses to pay a damage claim due to improper packing or lack of insurance.

5-2. PARTS ORDERING

Replacements for any of the components used in the Amplifier or Power Supply may be ordered, at a nominal cost, from the factory at the address above. Parts orders should specify that the parts are for the Amplifier or the Power Supply, the serial number of the unit, schematic reference designation of the part, and value, tolerance and voltage rating, where applicable.

WARNING

DO NOT operate the L 7 with the covers removed. DO NOT defeat the interlock. LETHAL VOLTAGE is present at various points inside the amplifier when the interlock is defeated.

Before disassembling or making any adjustments, perform these precautionary steps in sequence:

1. Disconnect the Power Supply from the power source.
2. Disconnect the AC Power connector from the amplifier.

3. Disconnect the High Voltage connector from the amplifier.
4. Reverse the above order to reassemble the Amplifier.

5-3. AMPLIFIER DISASSEMBLY

The cabinet is secured by 6 screws, 3 on each side of the unit. Remove the screws and lift off the cabinet.

There are three easily removable plates on the bottom of the amplifier chassis. The rear plate (with vent slots) covers the tube sockets and relay and can be removed by removing the 8 mounting screws.

The plate behind the POWER and MODE controls allows access to the input low pass filter and the 120/240 volt filament transformer primary winding jumpers. It is held in place with five screws.

Finally, the small plate underneath the band-switch conceals the input matching network. Unscrew the two mounting screws to remove this plate.

5-4. CLEANING

Since the Amplifier compartment is forced-air cooled, it will collect particles of dust which must be removed periodically. When the fan blade accumulates a large amount of dust, the Amplifier should be cleaned. The best way to clean the Amplifier is to remove the cabinet and blow the dust out with compressed air. If compressed air is not available, a 1 inch paint brush with soft bristles may be used to brush the interior clean.

5-5. TUBE REPLACEMENT

If it is necessary to replace the tubes in the L 7, use the same brand and type as the tubes removed or it may be necessary to retune the input coils as described in paragraph 5-10. If one tube is replaced its replacement should be the same brand and type as the remaining tube.

5-6. TEST EQUIPMENT

The following list of test equipment represents the minimum required to test and align the L 7.

- a. Ohmmeter

- b. 50 Ohm SWR Bridge
- c. Standard Milliammeter (400 mA)
- d. RF Wattmeter such as R. L. Drake Model WH 7 or an RF Voltmeter such as Hewlett-Packard Model 410B or Boonton Model 91CA.
- e. Transmitter with variable output to 100 W CW at 14 MHz.
- f. 50 Ohm Dummy Load
- g. 1-1/2 Volt Battery
- h. 10 Ohm Potentiometer
- i. Insulated Alignment Tool

5-7. AMPLIFIER TROUBLESHOOTING

Careful consideration has been given to the design of the L 7 to keep maintenance problems to a minimum. However, it is quite possible that some problem will arise which cannot be solved by tube substitution. If this occurs, we suggest that you return your unit to your dealer, or write directly to the R. L. Drake Company, Customer Service Department, describing your problem in detail. Include full information concerning external connections, control settings, associated equipment and antenna. Be sure to include the serial number of the amplifier.

L7 PLATE VOLTAGE

CW-TUNE

1900 Volts at No Load 1760 Volts at 0.565 Amps SSB

2600 Volts at No Load 2400 Volts at 0.800 Amps

L7 IDLING PLATE CURRENT (APPROX.)

TUBES	CW TUNE	SSB
Amperex 8802/3-500Z	0.100 Amps	0.160 Amps
Amperex 8163	0.100 Amps	0.160 Amps
Eimac 3-400Z	0.110 Amps	0.170 Amps
Eimac 3-500Z	0.170 Amps	0.220 Amps

All tubes above are directly interchangeable in the L 7 and are capable of operating the full legal limit for amateur service. All voltages and currents listed above bear a 10% tolerance for tube and line voltage variations.

5-8. TUBE CHECK

A common failure in the final amplifier tubes is a filament-to-grid short which is usually intermittent. This failure may be detected by the incidence of negative grid current (and usually some plate current) during standby. Check each suspect tube as follows:

- a. Observe the WARNING in paragraph 5-2 and remove the tubes.
- b. Attach an ohmmeter between the grid and fila-

ment of the tube to be tested. Good tubes will indicate infinite resistance. Bad tubes will indicate a short circuit. Intermittent tubes will indicate a momentary short when tapped lightly.

5-9. ALIGNMENT PROCEDURES

Refer to figures 5-1 and 5-2 as required to locate the components requiring adjustment.

5-10. INPUT COIL ADJUSTMENT

The input coils may have to be retuned if the final amplifier tubes are replaced with a type different from the tubes removed. Also, they may have to be retuned if it is desired to operate the amplifier outside the amateur bands. To retune the input coils proceed as follows:

- a. Disconnect the L 7 Power Supply from the power source.
- b. Remove the bottom cover from the Power Supply.
- c. Remove all of the jumpers from the 7-terminal barrier strip in the power supply. This allows the filaments, relay power and blower to operate without the high voltage being on.
- d. Remove the cabinet from the Amplifier. DO NOT defeat the interlock.
- e. Connect the Amplifier to the exciter as for normal operation EXCEPT: insert a 50 Ohm SWR bridge in the line (R. L. Drake WH-7 or equal).
- f. Preset the amplifier controls as follows:
BAND: on band to be tuned.
LOAD: fully counterclockwise to zero.
STBY: released (out)
ON-OFF to OFF.
- g. Tune the exciter, on CW, to the middle of the band to be tuned.
- h. Reconnect the Power Supply to the power source.
- i. Turn on the L 7 and increase the output from the exciter until the Grid meter reads 0.400 Amperes.
- j. Tune the PLATE control for a dip in plate current.
- k. Refer to figure 5-1. Turn the slug in the correct input coil for a minimum reflected power reading on the SWR bridge.
- l. Repeat steps f through k for each coil to be retuned.

NOTE

As shipped from the factory, the input coils are adjusted for the center of each band and are broad enough to cover the entire band.

- m. Turn off the Amplifier, disconnect the Power Supply from the power source, replace the jumpers removed in step c above, remove the SWR bridge and replace the covers on the Power Supply and the Amplifier before resuming operation.

5-11. METER ADJUSTMENT

To adjust the meters on the front panel of the L 7 proceed as follows:

- a. Disconnect the Power Supply from the power source.
- b. Remove all connections to the amplifier.
- c. Take the cabinet off the L 7 by removing the six screws that secure the cabinet on the bottom of the amplifier.
- d. Each meter has a conventional zero-adjust screw on the lower face of the meter and may be set to zero with that screw. To access these screws, remove the meters by unscrewing the two mounting tabs on each side of each meter.
- e. If resistor R20 is replaced the grid current shunt R16 will have to be calibrated as follows:
 - 1. Defeat the interlock on the top of the chassis by placing a book on top of the operating rod (NO CONNECTIONS TO AMPLIFIER).
 - 2. Set the Meter switch to GRID CURRENT.
 - 3. Make the connections show in figure 5-3.
 - 4. Adjust the 10 Ohm pot until the milliammeter indicates 0.400 Amperes.
 - 5. Adjust R19 until the Grid Current meter indicates 400 mA.
 - 6. Disconnect the test network.
- f. If a milliammeter is not available, an alternate method of calibrating R19 is as follows:
 - 1. Defeat the interlock (NO CONNECTIONS TO AMPLIFIER).
 - 2. Reverse the wires connected to the Plate Meter M1.
 - 3. Connect a 1-1/2 Volt battery (negative to ground) in series with a 10 Ohm potentiometer to pin 6 of the Power connector J4 on the rear of the amplifier.
 - 4. Adjust the 10 Ohm pot until the Plate Meter indicates 0.400 Amperes.
 - 5. Adjust R19 until the Grid Current meter indicates 400 mA.
 - 6. Disconnect the test network and reverse the wires on the Plate Meter to their original locations.
- g. The high voltage adjustment potentiometer R17 is not user adjustable. If this needs readjustment, return the L 7 to the factory for service. See paragraph 5-1.

5-12. WATTMETER CALIBRATION

The wattmeter in the L 7 was designed to keep maintenance to a minimum. The wattmeter is a passive device, and it should provide years of service and maintain its calibration. If calibration becomes necessary, paragraphs 5-13 through 5-16 must be followed in sequence.

5-13. NULL ADJUSTMENT

WARNING

When making adjustments to the Wattmeter with the exciter on, exercise EXTREME CAUTION to avoid RF burns. Avoid touching the Piston Trimmer C53, the Antenna Changeover Relay RLY1 and all wires connected to it.

- a. With the L 7 completely disconnected, turn it upside-down and remove the rear bottom cover.
- b. Connect the exciter to the RF INPUT and the 50 Ohm Dummy Load to the RF OUTPUT.
- c. Set the L 7 Meter switch on REF 300.
- d. Apply between 100 and 300 Watts of power at 14 MHz.
- e. With the insulated alignment tool adjust the piston trimmer C53 for a minimum indication of reflected power.
- f. All further adjustments should be made with the L 7 in its normal upright position.

5-14. 300 WATTS REFLECTED

- a. Connect the exciter to the RF OUTPUT and the RF INPUT to a Wattmeter (Drake WH 7) and then to a 50 Ohm Dummy Load.
- b. Set the Meter switch to REF 300 and apply 300 watts from the exciter. If 300 watts is not available, adjust the exciter for maximum RF output.
- c. Adjust R24 so that the L 7 wattmeter agrees with the standard wattmeter or with the RF power calculated from the RF voltage measured across the 50 ohm load.

5-15. 300 WATTS FORWARD

- a. Connect the L 7 as in the null adjustment (paragraph 5-15), and include a wattmeter (Drake WH-7) between RF OUTPUT and the 50 Ohm load. Place the Meter switch on FWD 300 and apply 300 watts from the exciter. If 300 watts is not available, adjust the exciter for maximum RF output.
- b. Adjust R23 so that the L 7 wattmeter agrees

with the standard wattmeter or with the RF power calculated from the RF voltage measured across the 50 Ohm load.

5-16. 3000 WATTS FORWARD

- a. After the 300 watts forward calibration, set the L 7 bandswitch to 20 meters and tune it up as described in Chapter 3, "Operation." Place the meter switch in the FWD 300 position adjust the exciter for 1000 watts output from the amplifier.
- b. Adjust R26 so that the L 7 wattmeter agrees with the standard wattmeter or with the RF power calculated from the RF voltage measured across the 50 ohm load.

5-17. KNOB POINTER ALIGNMENT

When replacing the knobs on the L 7 amplifier, correct alignment of the PLATE and LOAD controls is important. All of the other controls have flats on the control shafts and the setscrews in the knobs should press against the flats. The PLATE and LOAD control shafts should be rotated so that the plates of the variable capacitor are fully meshed, and the pointer should be resting in a nine o'clock position at the end of the tuning arc.

5-18. POWER SUPPLY CIRCUIT BREAKER RESET

There are two buttons on the power supply which are provided for resetting the circuit breakers in case they should trip from overloading. If the circuit breakers trip, turn off the amplifier and wait for one minute before resetting. If the circuit breakers trip immediately after resetting and turning the amplifier on, an investigation should be made to determine the cause of the overload.

5-19. REMOVING THE BOTTOM COVER

WARNING

BE SURE that the L 7 Power Supply is unplugged from its power source.

After completely disconnecting all sources of power, the bottom cover of the Power Supply can be removed by taking out all of the screws around the bottom of the chassis.

5-20. REMOVING TOP COVER

WARNING

BE SURE that the L 7 Power Supply is unplugged from its power source.

The top cover cannot be removed until the bottom cover has been removed. After the bottom has been removed, remove the line cord wires from the barrier strip and ground. The top can then be removed by taking out the remaining screws holding the top cover to the chassis.

5-21. POWER SUPPLY TROUBLESHOOTING

Careful consideration has been given to the design of the L 7 Power Supply to keep maintenance problems to a minimum. However, if the Power Supply fails to function, first check the circuit breakers and reset them if it is necessary. If the circuit breakers continue to trip, check for short circuits in the high voltage line. Especially be certain that the high voltage interlock in the Amplifier is not shorting the high voltage to ground as it is supposed to do when the top cover is taken off the amplifier. If the circuit breakers have been tripped because of a short in the high voltage line, a continuity check should be given to each silicon diode bank in the Power Supply to determine if either or both banks have failed. In the event of a short circuit, resistor R12 in the Power Supply will be destroyed. This resistor protects the diodes in the Power Supply and it should be replaced with an IRC 0.82 Ohm 2 Watt type BWH resistor ONLY. In the event of a difficulty we recommend that you return your unit to your dealer, or write directly to our Customer Service Department describing your problem in detail. Include full information concerning the circumstances during the failure, any measurements that were made and be sure to include the serial number.

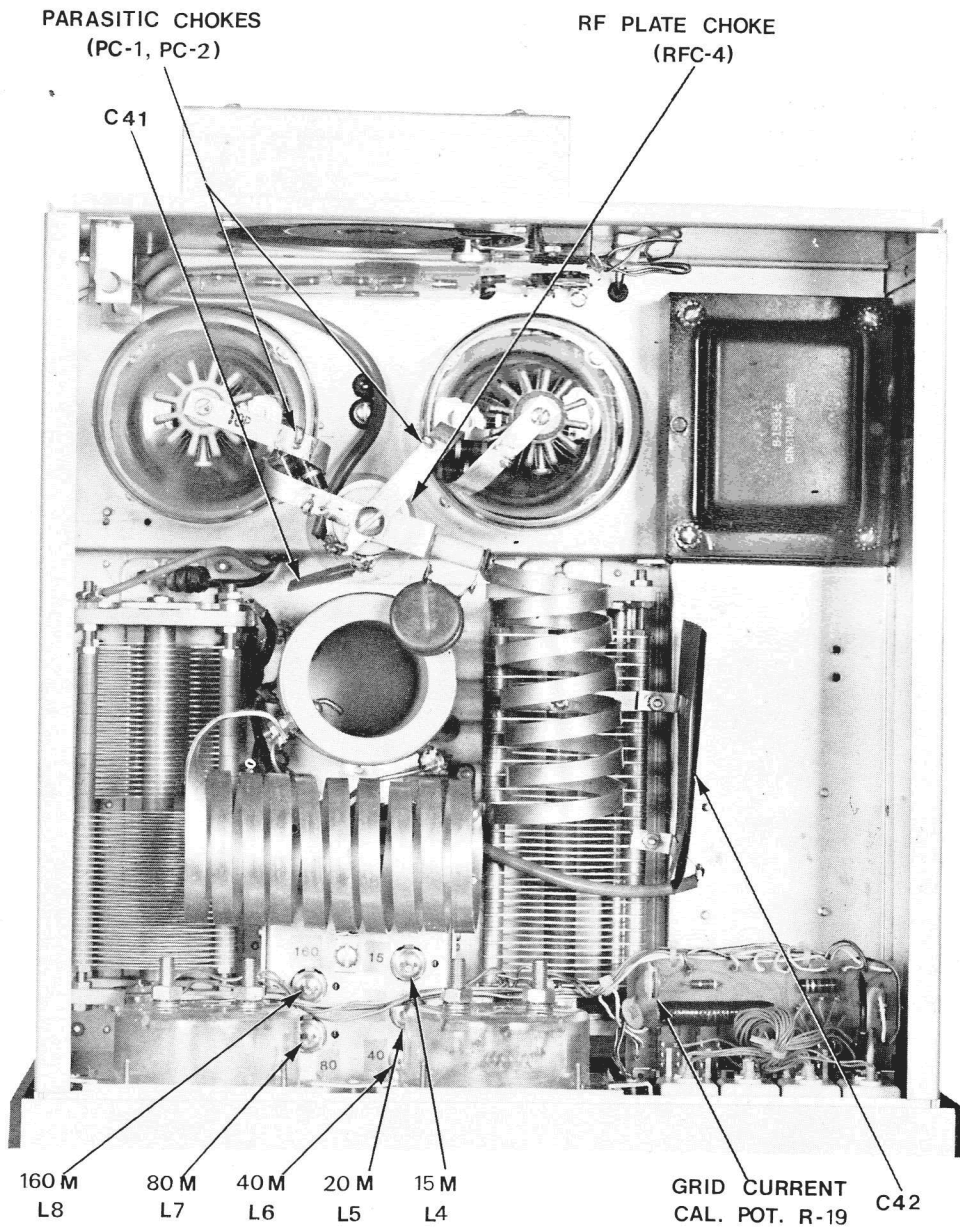

Fig. 5-1 Component Locations, Top View

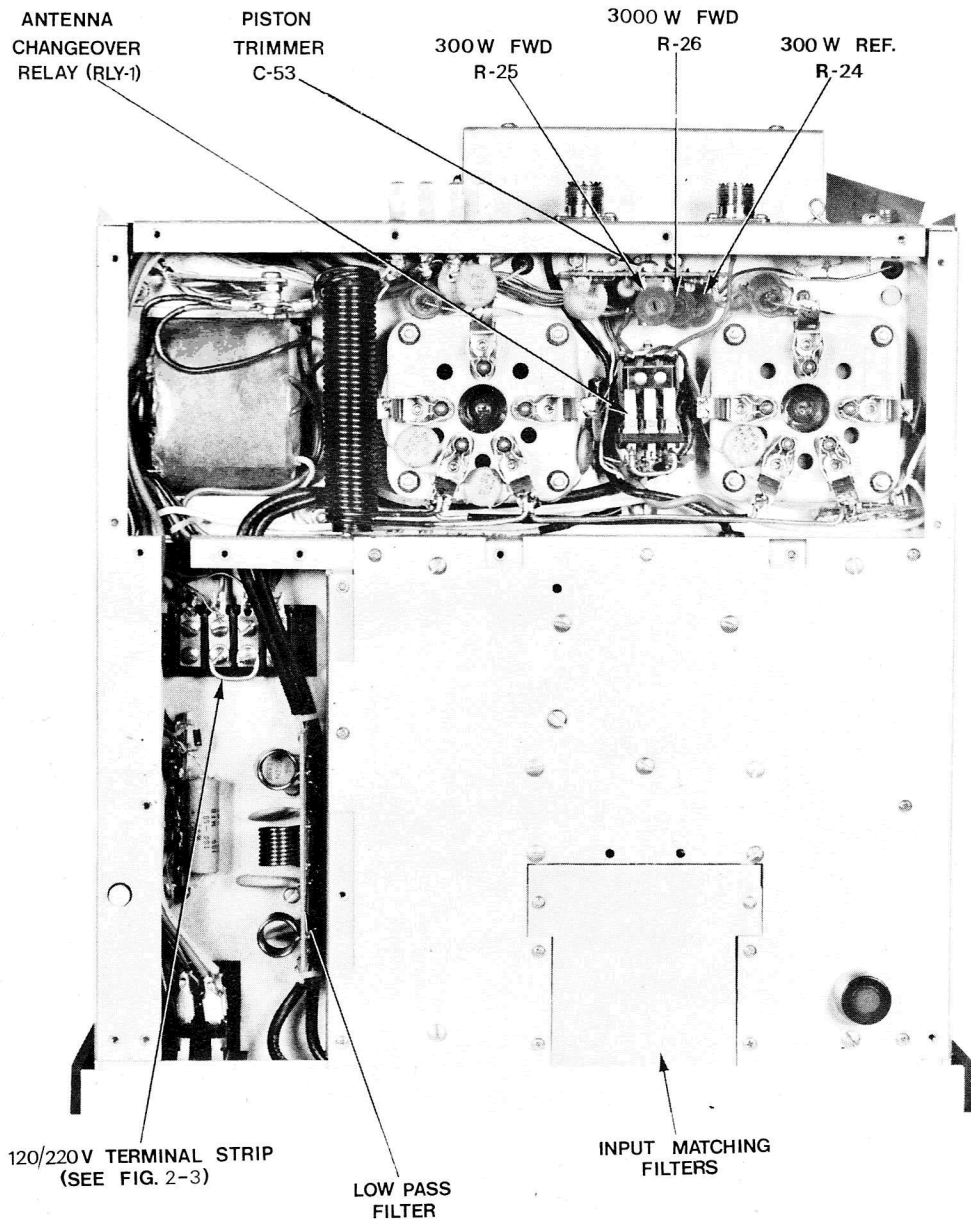
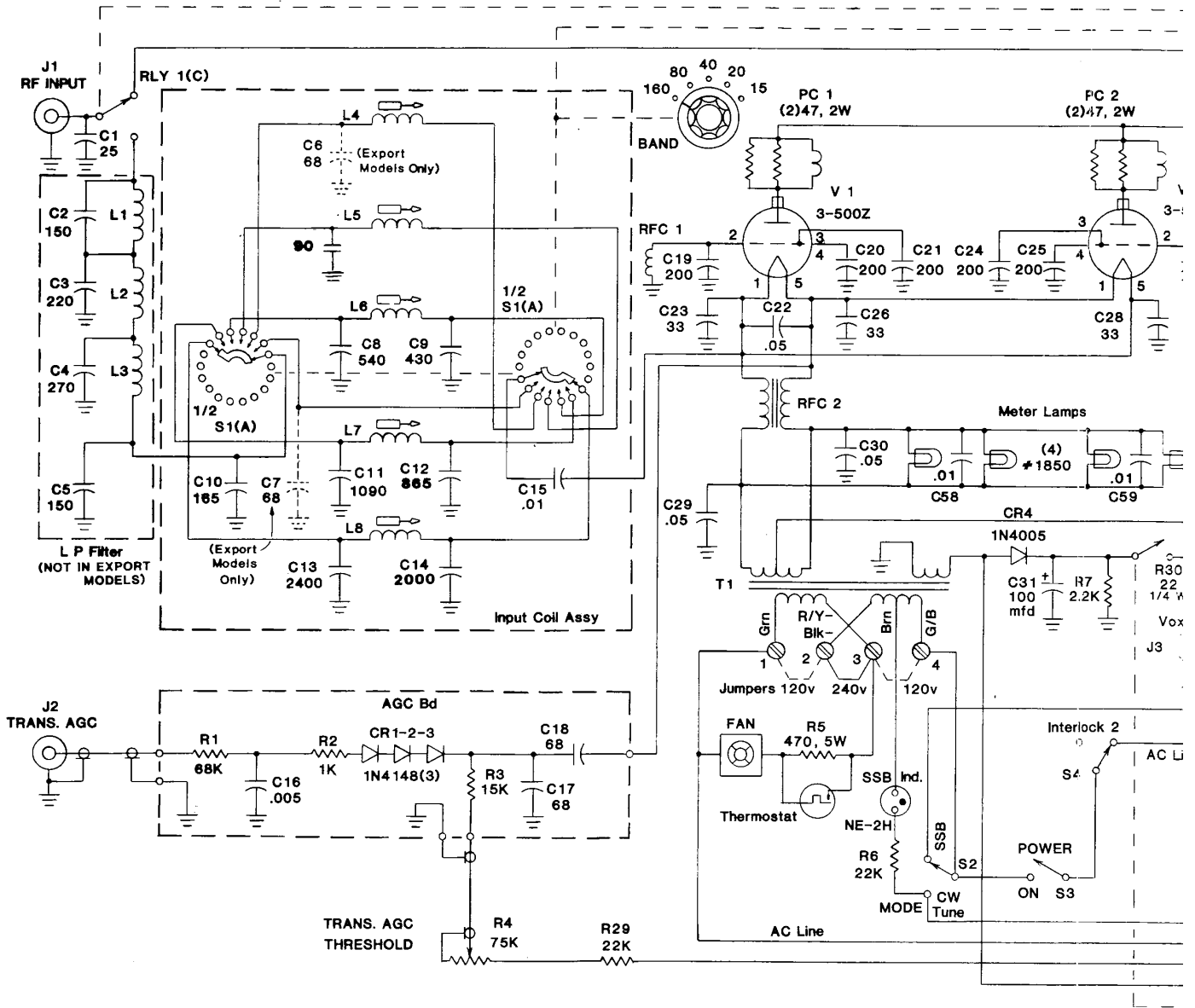

Fig. 5-2 Component Locations, Bottom View

NOTES

Component Locations

R	1	2	3	29	5	6	7
C	1 3 2 4 5	10 16	6 11 8 13	12 14 9	15 17 18	19 29 23	22 20 30 21 26 58 24 25 31 59 28
L	1 2 3		4 6 5 7 8				



NOTE

Capacitors marked 1.0 to 2400 are in pf, and Capacitors marked .001 to .1 are in mfd unless otherwise noted.

	7	30	8	9	10	11	12	13	14	18	15	17	22	25	23	21	24	32	27				
3	24	25	59	27	32	60	34	35	39	41	45	46	47	61	48	42	43	55	54	62	56	63	57
										9	11												13
										10													

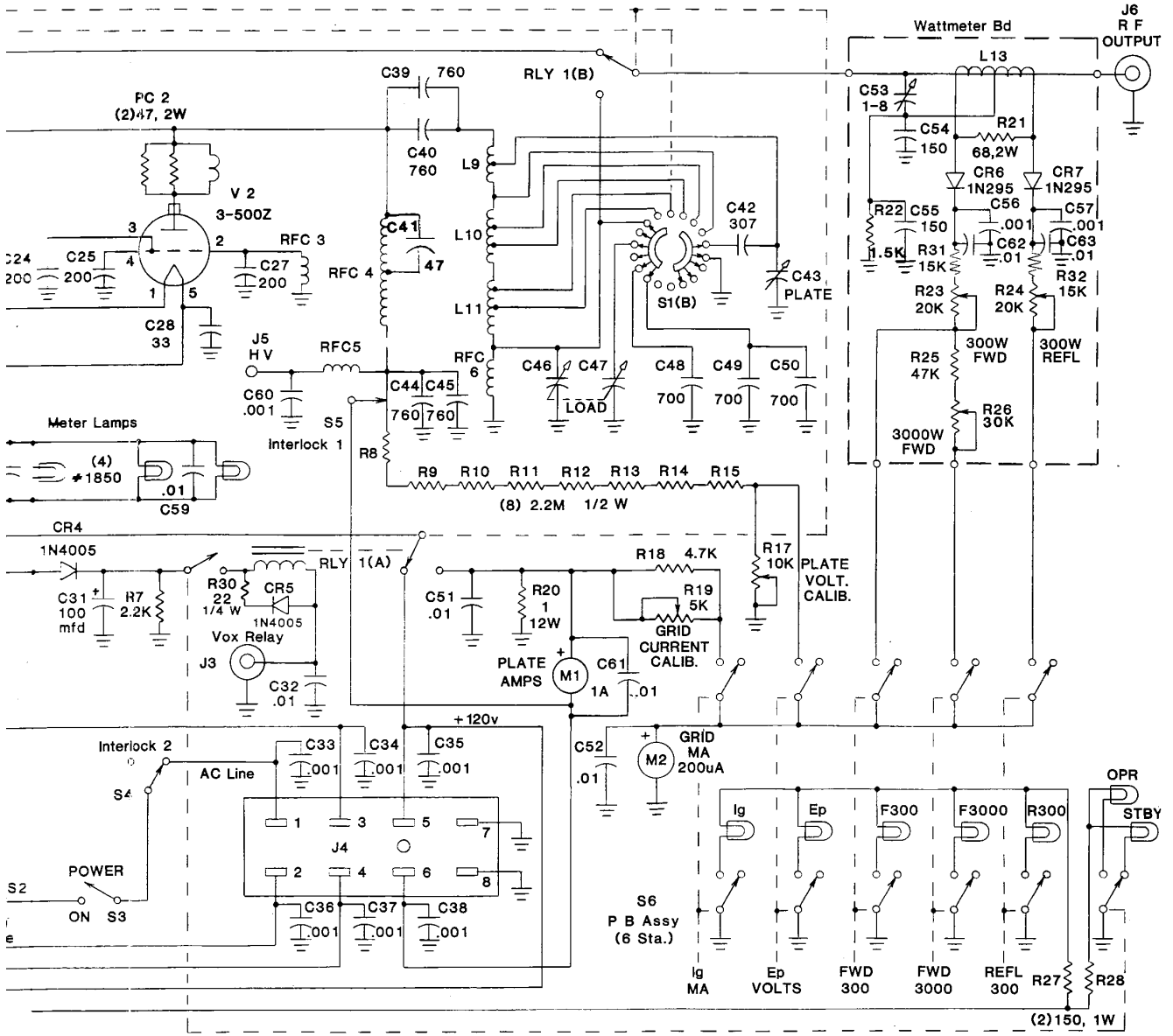

301800801

4-80

Dwg #D4788

Fig. 5-5 Model L7 Linear Amplifier Schematic Diagram

Component Locations

R	1	2	3	29	5	6	7	30	8	9	10	11	12	13	14	15	17	22	25	26	27	28	32	33	34	35	36	37	38	39	40	41	42	43	46	47	48	49	50	51	52	53	54	55	56	57																																																						
C	1	3	5	10	16	7	8	11	12	14	9	15	17	18	19	20	21	22	23	24	25	26	28	29	30	31	32	33	36	37	38	40	44	45	46	47	61	62	63	64	65	66	68	69	70	71	72	73	74	75	76	77	78	79	80	81	82	83	84	85	86	87	88	89	90	91	92	93	94	95	96	97	98	99	100																									
L	1	2	3	4	5	6	7	8	9	10	11	12	13	14	15	16	17	18	19	20	21	22	23	24	25	26	27	28	29	30	31	32	33	34	35	36	37	38	39	40	41	42	43	44	45	46	47	48	49	50	51	52	53	54	55	56	57	58	59	60	61	62	63	64	65	66	67	68	69	70	71	72	73	74	75	76	77	78	79	80	81	82	83	84	85	86	87	88	89	90	91	92	93	94	95	96	97	98	99	100

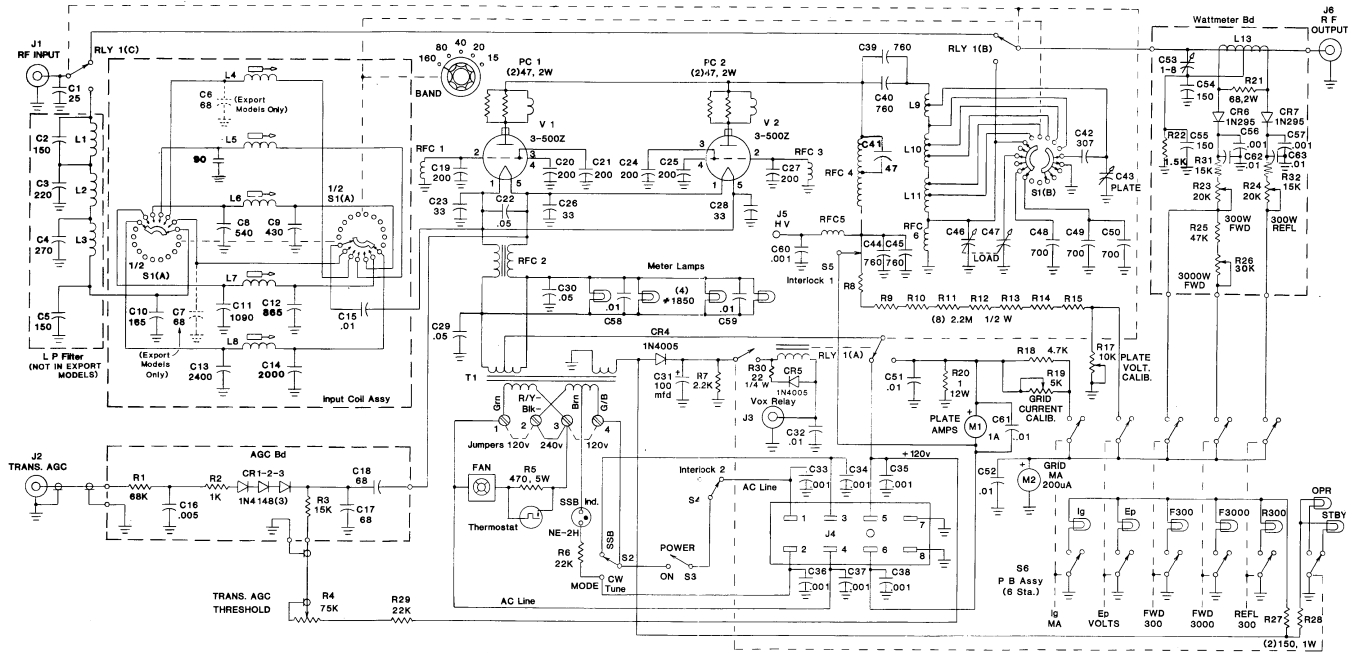

301800801

NOTE

Capacitors marked 1.0 to 2400 are in pf, and Capacitors marked .001 to .1 are in mfd unless otherwise noted.

4-80

Dwg #D4788

Fig. 5-5 Model L7 Linear Amplifier Schematic Diagram